

Date Created: 29/08/2016

Product: Pegasus S3/S4

Title: Remove Spindle Pulleys, Fit and Reset Spindle Pulleys, Fit and Tension Belts



SAFETY! Before attempting to make any adjustments or carry out maintenance on the mower, review the hazard identification table (section 3a of your Operator Manual) and take all necessary precautions.

Single Spindle Pulley Removal

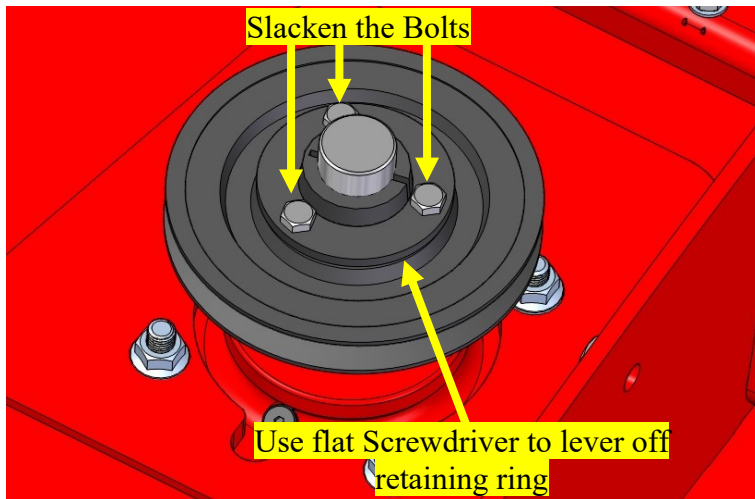

To remove a single spindle pulley, slacken the three M8 x 20 Bolts fitted through the Retaining by around **10mm (3/8")**

Fit a flat bladed screwdriver between the Pulley and Retaining Ring. Use the screw driver as a lever to release the Retaining Ring from the Biloc Bush.

Work around the Pulley evenly while doing this until the Retaining Ring is loose on the Bush.

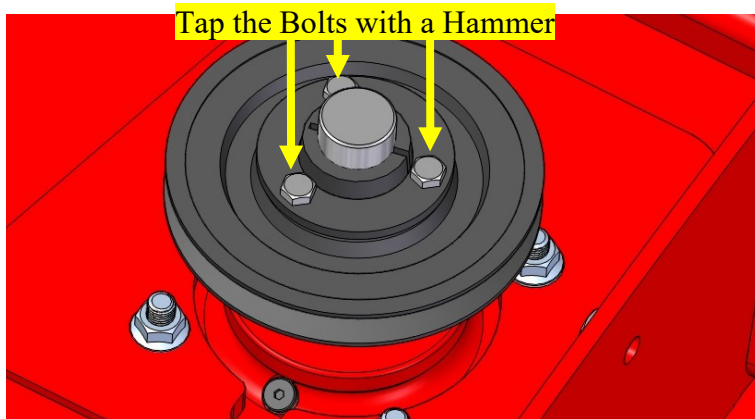

Tap each of the Bolt Heads firmly with a hammer.

Work around the Pulley evenly while doing this until the Pulley is loose on the Bush.

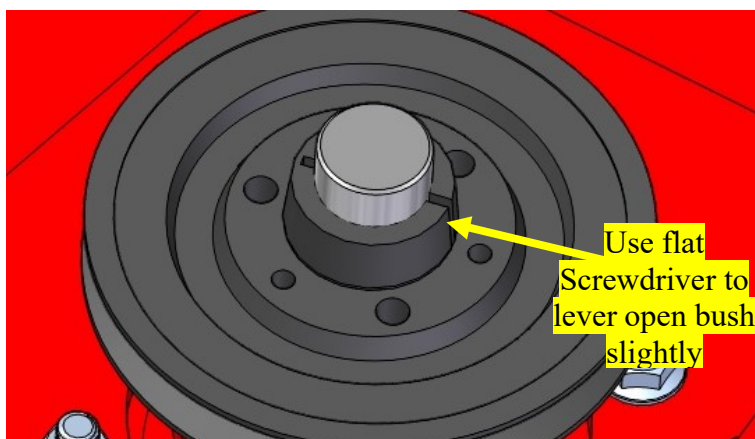

Remove the three M8 x 20 Bolts from the Pulley.

Remove the Retaining Ring.

Insert the flat bladed screwdriver into slot present in the Biloc Bush.

Use this as a lever to gently prise the Biloc Bush open slightly.

With the screwdriver still in place, slide the Bush up and off the Spindle Shaft.

Remove the Pulley from the Spindle Shaft.

Double Spindle Pulley Removal

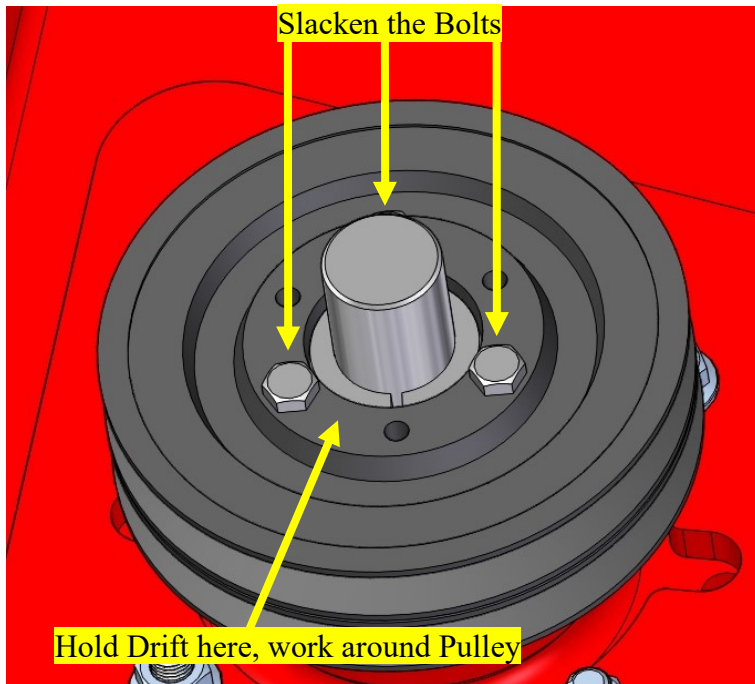

To remove a Double spindle pulley, slacken the three M8 x 40 Bolts fitted through the Pulley by around **10mm (3/8")**

Hold a suitable drift against the Centre Boss of the **TOP** pulley and hit it with a hammer. Work around the Centre Boss of the Pulley.

This should jar the bush sufficiently to loosen the taper and the pulley should become free.



Note:

The Centre Boss is the section of the Pulley that the Bolts run through!

DO NOT hit against the outer rim of the pulley or it will break!

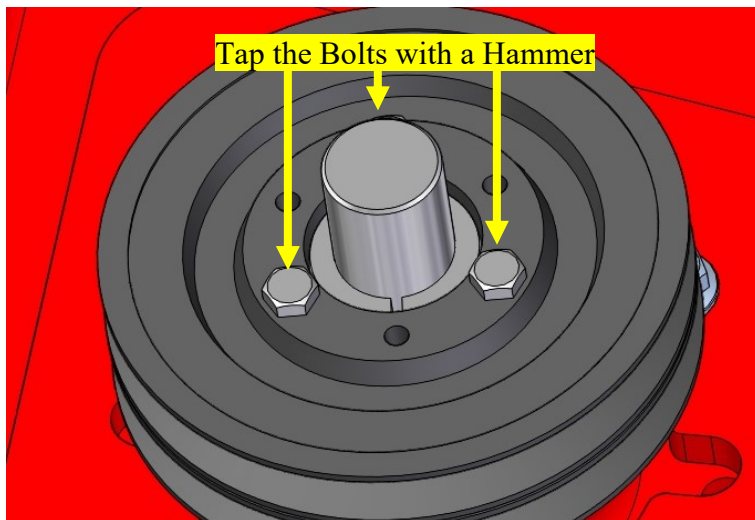

Tap each of the Bolt Heads firmly with a hammer.

Work around the Pulley evenly while doing this until the **BOTTOM** Pulley is loose on the Bush.

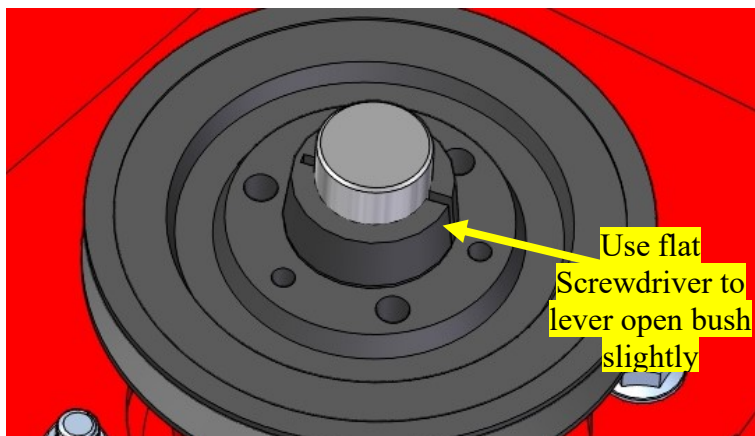

Remove the three M8 x 40 Bolts from the Pulley.

Remove the Top Pulley.

Insert a flat bladed screwdriver into slot present in the Biloc Bush.

Use this as a lever to gently prise the Biloc Bush open slightly.

With the screwdriver still in place, slide the Bush up and off the Spindle Shaft.

Remove the Pulley from the Spindle Shaft.

Single and Double Spindle Pulley Preparation



Clean **ALL** Pulley Components of contaminants using white spirits and a rag.

Clean the Spindle Shaft using white spirits and a rag.

If the Spindle Shaft is corroded, fine emery tape can be used to remove the corrosion!

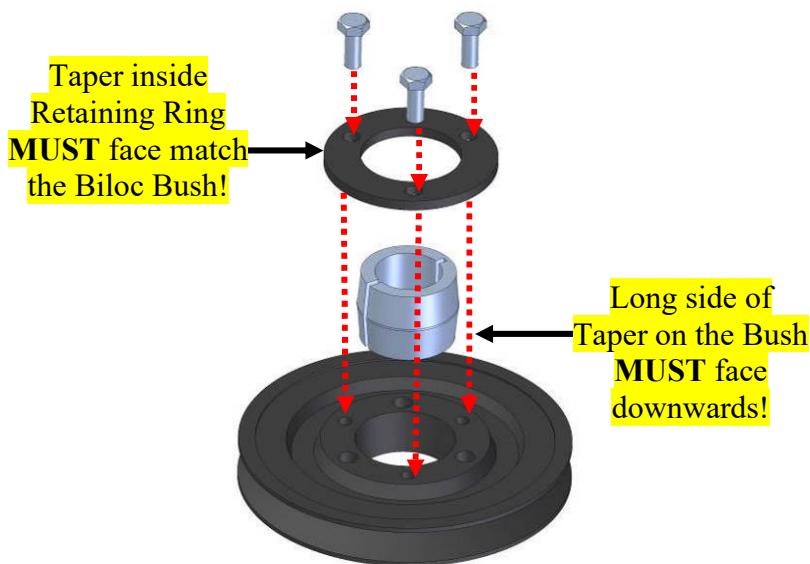

Assemble the Single Spindle Pulleys as shown.

The **LONG** taper side of the Biloc bush **MUST** face downwards!

The Taper inside the Retaining Ring **MUST** match the Taper of the Biloc Bush!

Wind the M8 x 20 Bolts into the three tapped holes in the Pulley.



Note:

DO NOT tighten the M8 x 20 bolts at this stage!

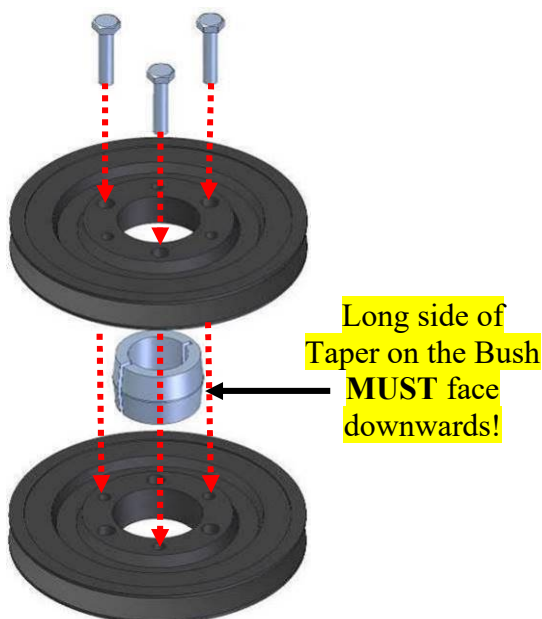

Assemble the Double Spindle Pulleys as shown.

The **LONG** taper side of the Biloc bush **MUST** face downwards!

Feed the M8 x 40 Bolts through the Blank holes in the **TOP** Pulley.

Wind the M8 x 40 Bolts into the three tapped holes in the **BOTTOM** Pulley.



Note:

DO NOT tighten the M8 x 40 bolts at this stage!

Pulley Layout

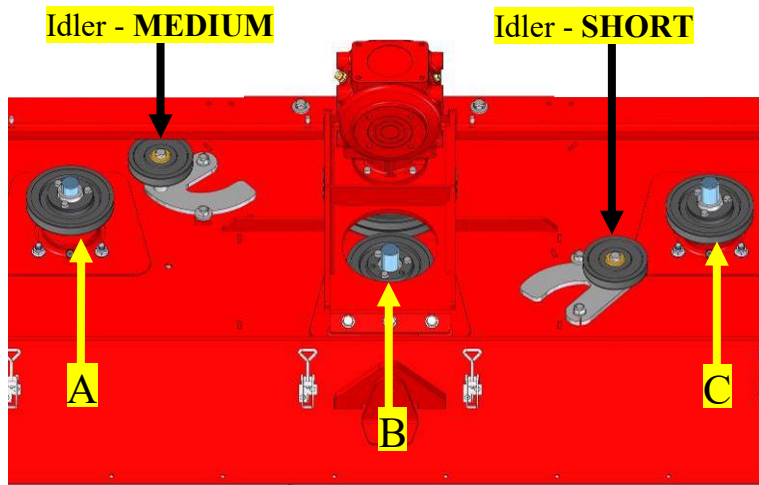

493/16' ALL Decks 610/20' Rear Deck

Shown opposite is the Spindle Pulley and Idler Layout.

A: is a **SINGLE SPINDLE PULLEY**, set to the height of the Idler - **MEDIUM** assembly.

B: is a **DOUBLE SPINDLE PULLEY**, set centralized with the Gearbox Pulley.

C: is a **SINGLE SPINDLE PULLEY**, set to the height of the Idler - **SHORT** assembly.

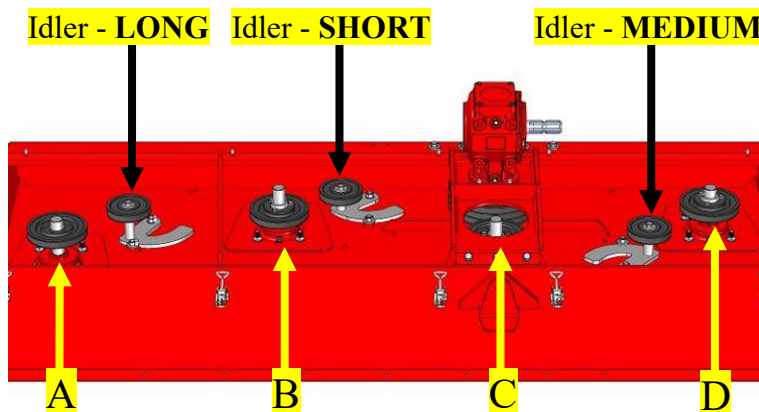

610/20' LEFT HAND DECKS ONLY

Shown opposite is the Spindle Pulley and Idler Layout for Pegasus and X-WAM.

A: is a **SINGLE SPINDLE PULLEY**, set to the height of the Idler - **LONG** assembly.

B: is a **SINGLE SPINDLE PULLEY**, set to the height of the Idler - **SHORT** assembly.

C: is a **DOUBLE SPINDLE PULLEY**, set centralized with the Gearbox Pulley.

D: is a **SINGLE SPINDLE PULLEY**, set to the height of the Idler - **MEDIUM** assembly.

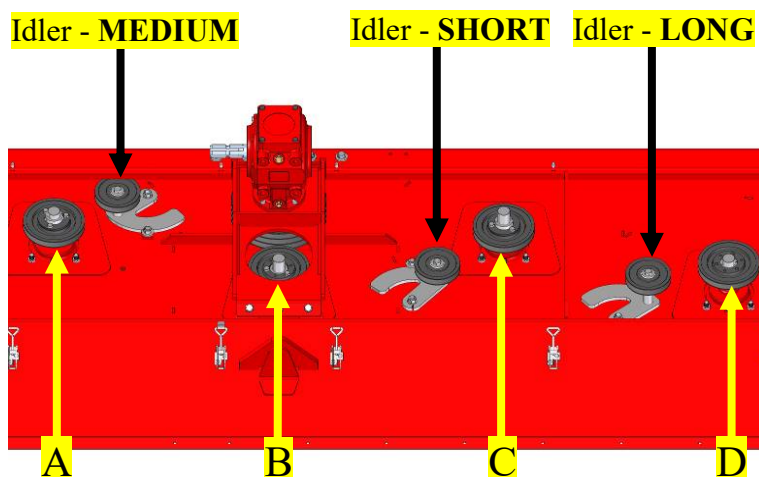

610/20' RIGHT HAND DECKS ONLY

Shown opposite is the Spindle Pulley and Idler Layout for Pegasus and X-WAM.

A: is a **SINGLE SPINDLE PULLEY**, set to the height of the Idler - **MEDIUM** assembly.

B: is a **DOUBLE SPINDLE PULLEY**, set centralized with the Gearbox Pulley.

C: is a **SINGLE SPINDLE PULLEY**, set to the height of the Idler - **SHORT** assembly.

D: is a **SINGLE SPINDLE PULLEY**, set to the height of the Idler - **LONG** assembly.

Pulley Fitment

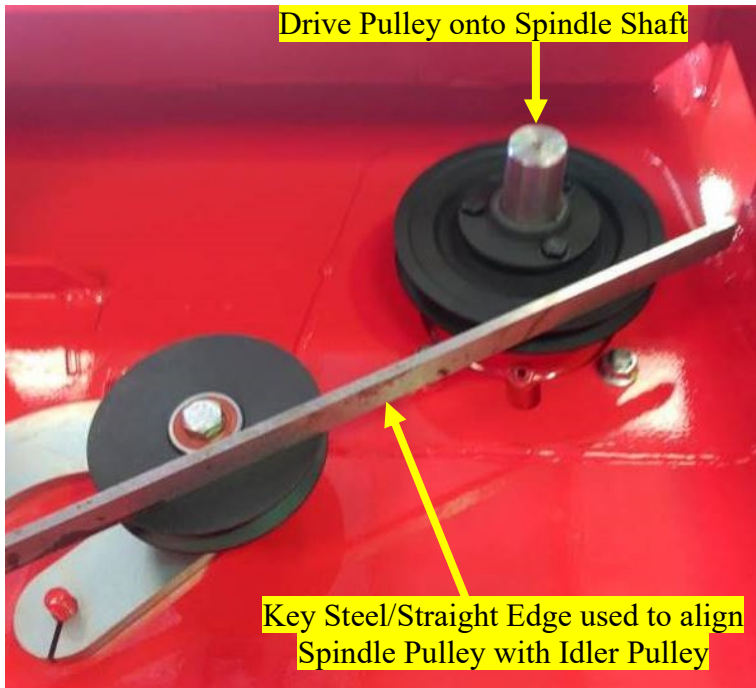

How to position and secure a SINGLE Spindle Pulley:

Gently drive the Single Spindle Pulley onto the Spindle Shaft using a Drift and a Hammer.

Using a length of Key Steel or a Straight Edge from the appropriate Idler Pulley, position the Single Spindle Pulley approximately **2mm (1/16") LOWER** than the appropriate Idler Pulley as it will pull up slightly when tightened.

See **ABOVE** for Spindle Pulley Layout details.



Note:

A section of steel tube/pipe that just fits over the Spindle Shaft is ideal to use as a Drift! Ensure the ends are cut square!

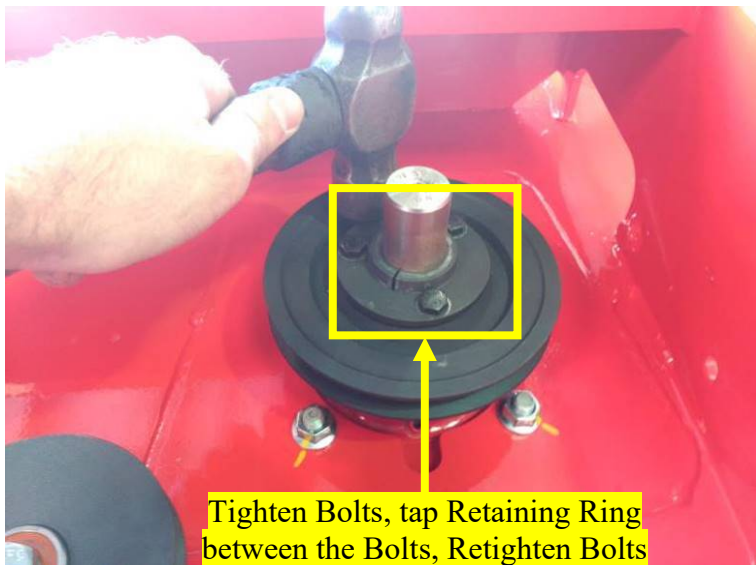

How to position and secure a SINGLE Spindle Pulley:

Tighten the three M8 x 20 bolts on the Spindle Pulley.

Ensure the Bolts are tightened evenly and gradually!

Tap the Retaining Ring between the Bolts with a Hammer and Retighten the Bolts.

Repeat this step twice more, this will ensure that the Biloc Bush, Retaining Ring and Pulley are seated together correctly!



How to position and secure a SINGLE Spindle Pulley:



Important:

It is critical that these pulleys are level with each other!

If they are **NOT**, reset the Spindle Pulley position and repeat the tightening process.

Double check Pulley Bolt tightness with a Spanner!

Drive Pulley onto Spindle Shaft

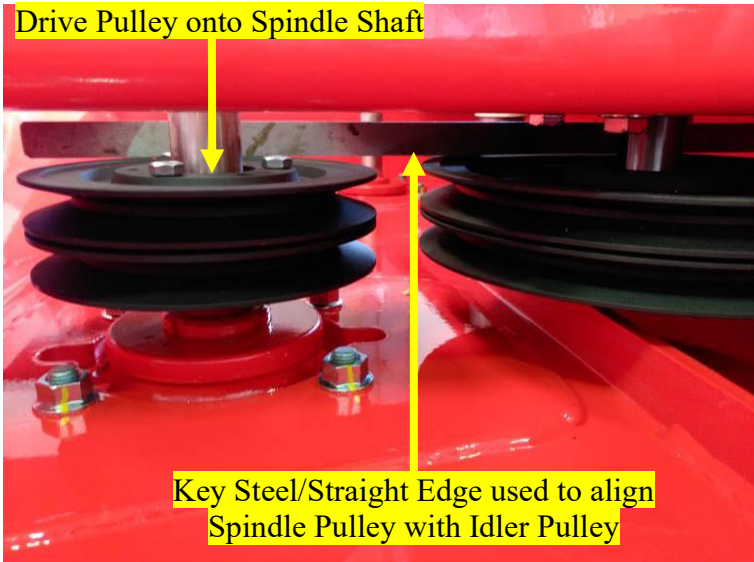

Key Steel/Straight Edge used to align Spindle Pulley with Idler Pulley

How to position and secure a DOUBLE Spindle Pulley:

Gently drive the Double Spindle Pulley onto the Centre Spindle Shaft using a Drift and a Hammer.

Line the Double Spindle Pulley up so that it is centralized with the Gearbox Pulley. A length of Key Steel/Straight Edge can be used to align the Pulleys.

See **ABOVE** for Spindle Pulley Layout details.



Note:

A section of steel tube/pipe that just fits over the Spindle Shaft is ideal to use as a Drift! Ensure the ends are cut square!

Torque to 25Nm (19ft lbs), tap Pulley between Bolts, re-torque to 25Nm (19ft lbs).

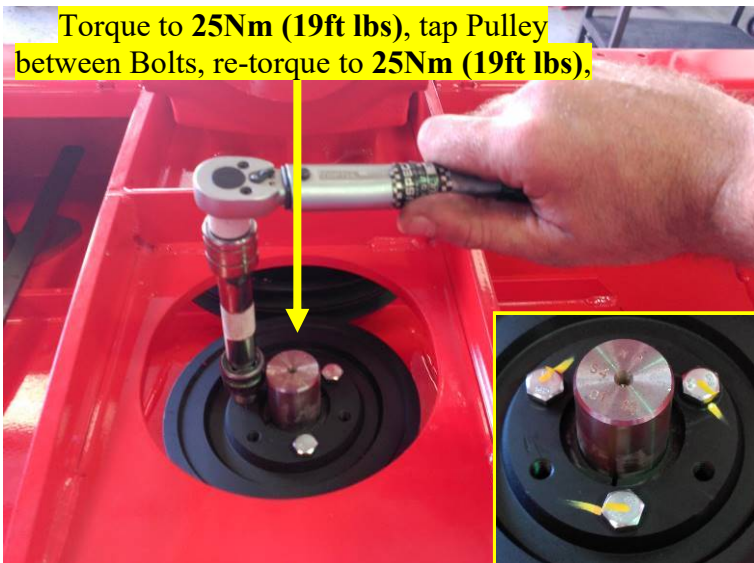

How to position and secure a DOUBLE Spindle Pulley:

Tighten the M8 x 40 bolts evenly to 25Nm (19ft lbs), using the Torque Wrench.

Tap the top pulley between each of the bolts, then re-torque to 25Nm (19ft lbs), Repeat the tapping / torquing process again then stripe bolts with a Paint Marker, see inset.

Repeat this step twice more, this will ensure that the Biloc Bush and Pulleys are seated together correctly!



Note:

The M8 x 40 bolts **MUST** be tightened evenly to keep the pulleys parallel!

Check Pulley alignment using Key Steel

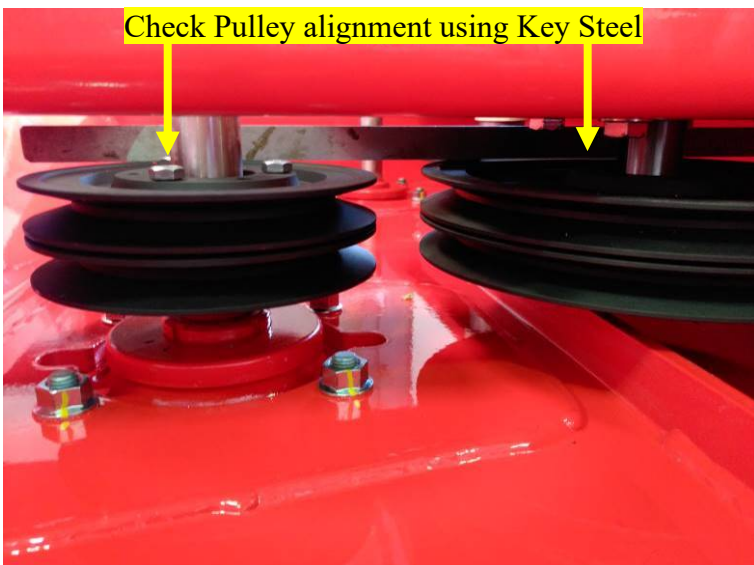

How to position and secure a DOUBLE Spindle Pulley:



Note:

It is critical that these Pulleys are aligned with each other!

Belt Fitment



493/16' ALL Decks 610/20' Rear Deck

Loosely fit a Belt (404-040-750) over the **CENTRE** Spindle Pulley from the **RIGHT HAND** side of the Body as shown.

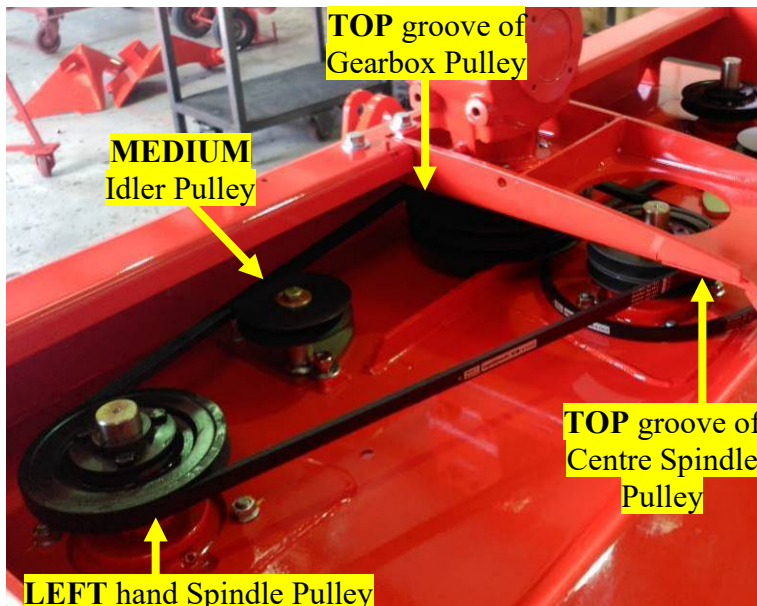

493/16' ALL Decks 610/20' Rear Deck

Fit the second Belt (404-040-750) over the **CENTRE** Spindle Pulley.

Pass the Belt **UNDER** the Gearbox Pulley.

Fit around the **TOP** groove of the **CENTRE** Spindle Pulley, around the **TOP** groove of the Gearbox Pulley, around the **MEDIUM** Idler Pulley and the **LEFT** hand Spindle Pulley.

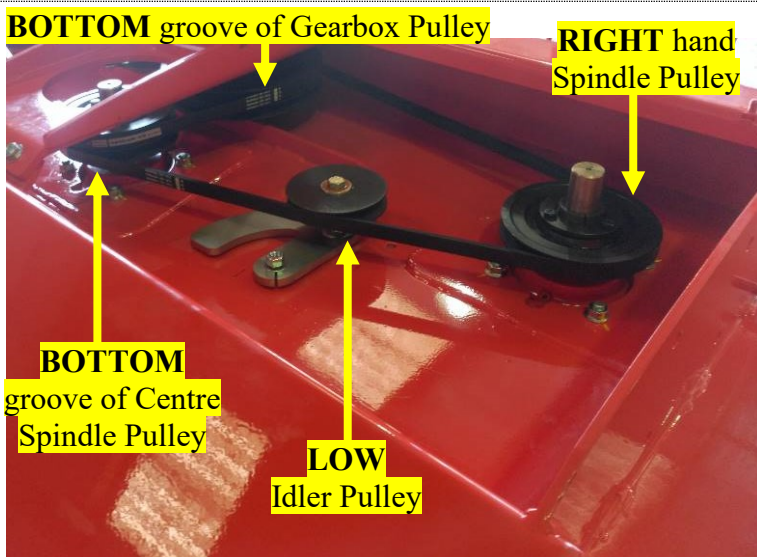

493/16' ALL Decks 610/20' Rear Deck

Pass the Belt **UNDER** the Gearbox Pulley.

Fit around the **BOTTOM** groove of the **CENTRE** Spindle Pulley, around the **BOTTOM** groove of the Gearbox Pulley, around the **LOW** Idler Pulley and the **RIGHT** hand Spindle Pulley.

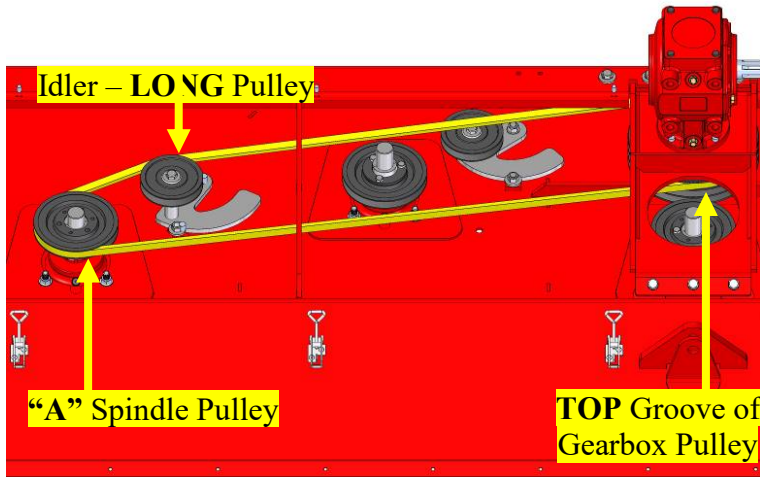

610/20' LEFT HAND DECKS ONLY

Fit the Long Belt (404-041-150) around the **TOP** Groove of the Gearbox Pulley, the Idler – **LONG** Pulley and the “**A**” Spindle Pulley as shown in **YELLOW**.



Note:

X-WAM Left Decks have the same Belt Layout as Pegasus!

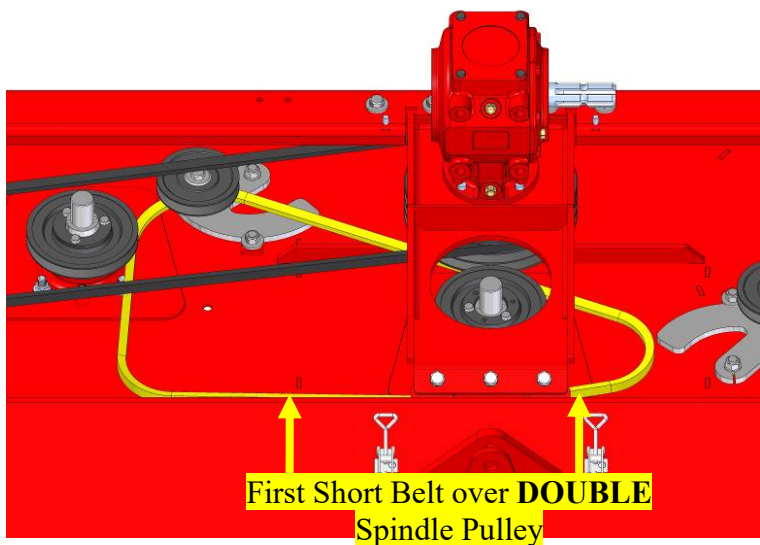

610/20' LEFT HAND DECKS ONLY

Loosely fit a Short Belt (404-040-750) over the **DOUBLE** Spindle Pulley from the **LEFT HAND** side of the Body as shown in **YELLOW**.



Note:

X-WAM Left Decks have the same Belt Layout as Pegasus!

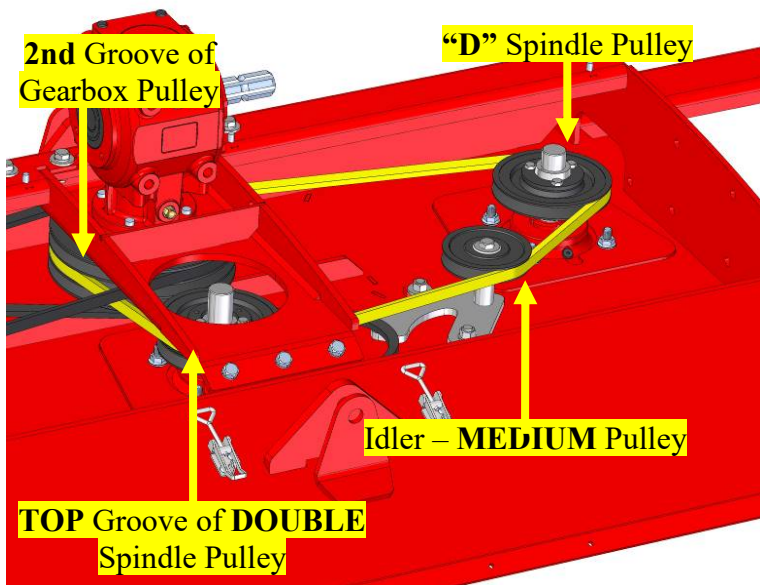

610/20' LEFT HAND DECKS ONLY

Fit the second Short Belt (404-040-750) over the **DOUBLE** Spindle Pulley.

Pass the Belt **UNDER** the Gearbox Pulley.

Fit around the **TOP** groove of the **DOUBLE** Spindle Pulley, around the **2nd** groove of the Gearbox Pulley, around the **MEDIUM** Idler Pulley and the “**D**” Spindle Pulley as shown in **YELLOW**.



Note:

X-WAM Left Decks have the same Belt Layout as Pegasus!

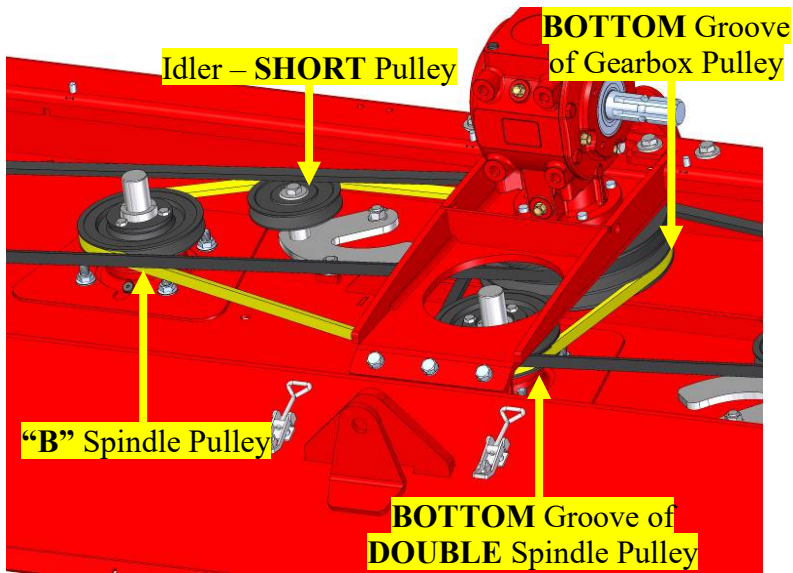

610/20' LEFT HAND DECKS ONLY

Pass the first Short Belt **UNDER** the Gearbox Pulley.

Fit around the **BOTTOM** groove of the **DOUBLE** Spindle Pulley, around the **BOTTOM** groove of the Gearbox Pulley, around the **SHORT** Idler Pulley and the **"B"** Spindle Pulley as shown in **YELLOW**.



Note:

X-WAM Left Decks have the same Belt Layout as Pegasus!

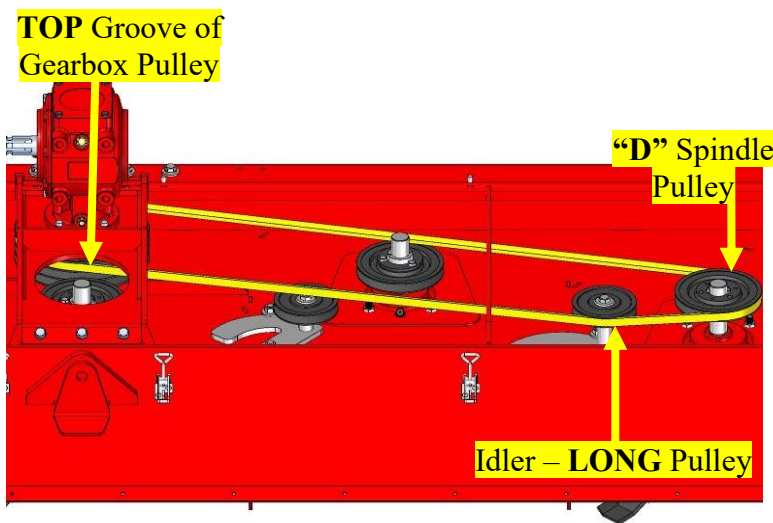

610/20' RIGHT HAND DECKS ONLY

Fit the Long Belt (404-041-150) around the **TOP** Groove of the Gearbox Pulley, the Idler - **LONG** Pulley and the **"D"** Spindle Pulley as shown in **YELLOW**.



Note:

X-WAM **RIGHT** Decks have the same Belt Layout as Pegasus!

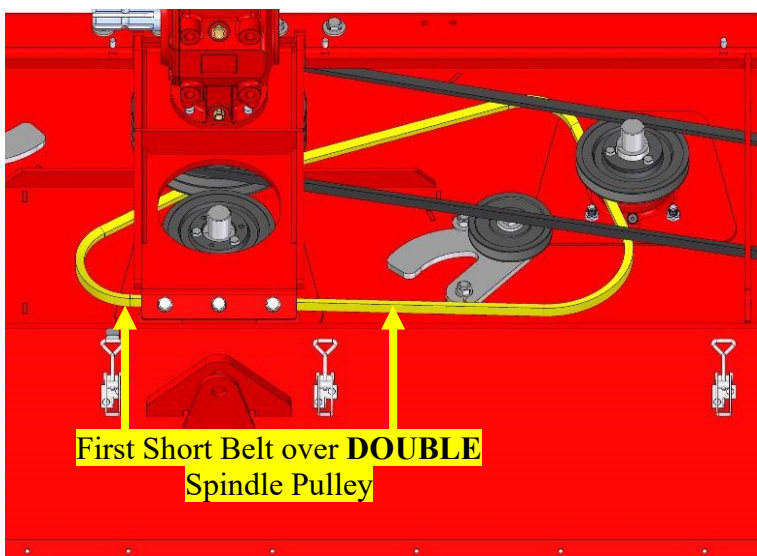

610/20' RIGHT HAND DECKS ONLY

Loosely fit a Short Belt (404-040-750) over the **DOUBLE** Spindle Pulley from the **RIGHT HAND** side of the Body as shown in **YELLOW**.



Note:

X-WAM **RIGHT** Decks have the same Belt Layout as Pegasus!

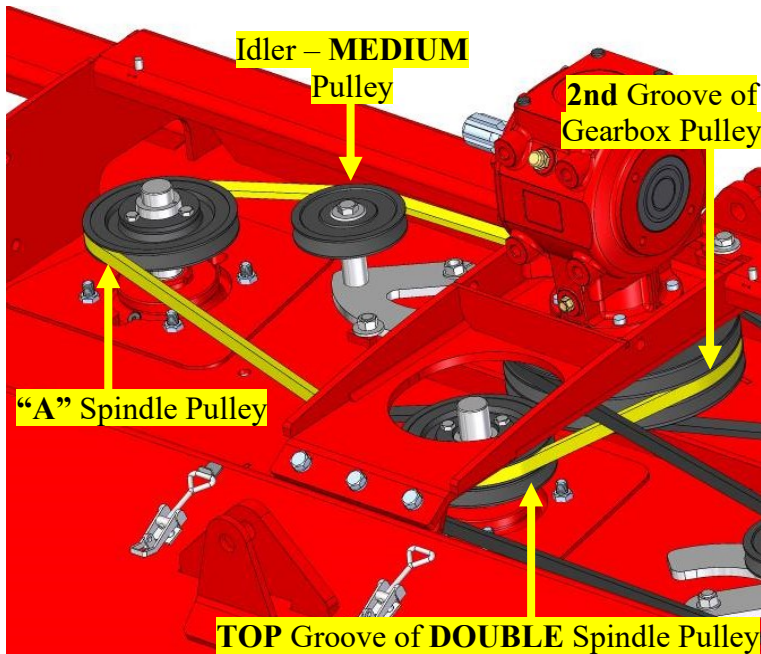

610/20' RIGHT HAND DECKS ONLY

Fit the second Short Belt (404-040-750) over the **DOUBLE Spindle Pulley**.
 Pass the Belt **UNDER** the Gearbox Pulley.
 Fit around the **TOP** groove of the **DOUBLE Spindle Pulley**, around the **2nd** groove of the Gearbox Pulley, around the **MEDIUM Idler Pulley** and the **"A"** Spindle Pulley as shown in **YELLOW**.



Note:
X-WAM RIGHT Decks have the same Belt Layout as Pegasus!

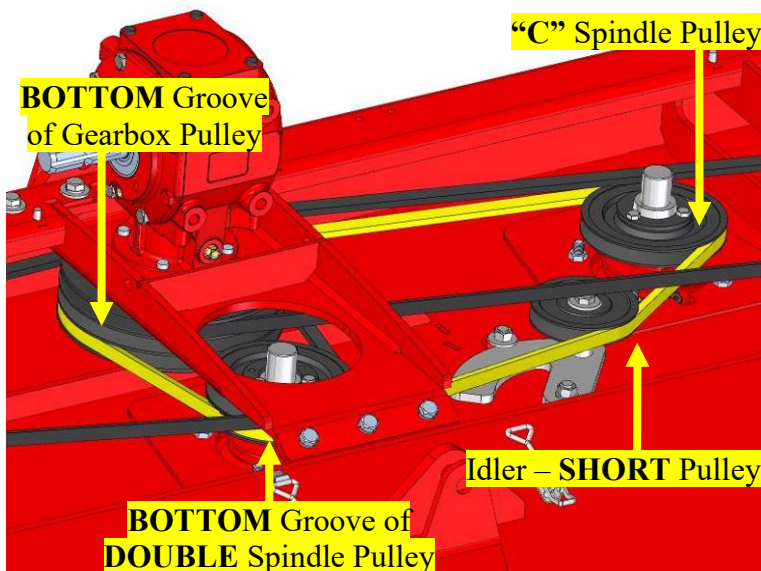

610/20' RIGHT HAND DECKS ONLY

Pass the first Short Belt **UNDER** the Gearbox Pulley.
 Fit around the **BOTTOM** groove of the **DOUBLE Spindle Pulley**, around the **BOTTOM** groove of the Gearbox Pulley, around the **LOW Idler Pulley** and the **"C"** Spindle Pulley as shown in **YELLOW**.



Note:
X-WAM RIGHT Decks have the same Belt Layout as Pegasus!

Belt Tensioning

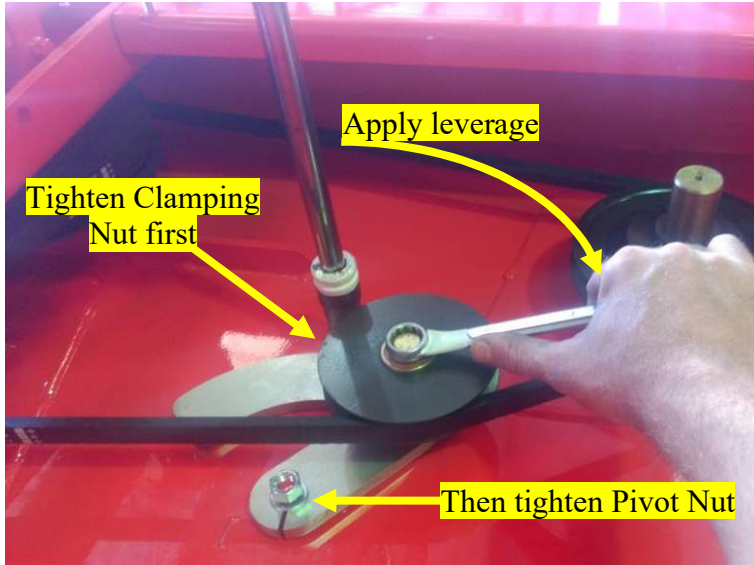

Tension each Belt by applying leverage to the Idler pulley bolt using a Spanner.

While maintaining the tension on the spanner, tighten the Clamping Nut, then tighten the Pivot Nut to secure the Idler in place.

One Idler shown.

Repeat this process for **ALL** Belts.



Note:

Belts should have **10-15mm (3/8"-9/16")** of belt deflection once tensioned.



Important:

Pull on one of the Belts to check that **ALL** Pulleys and Idlers rotate and that the Belts do not interfere with anything. Check Belt Tension is correct.

Belts should have **10-15mm (3/8"-9/16")** of belt deflection when tensioned correctly.

Re-tension if needed.

Please refer to your **operator's manual** for further instruction on belt tension!



Note:

Be wary about getting hands pinched between Pulleys and Belts!